

The Li-G4 range



CLAYTON
POWER

SAFETY INSTRUCTIONS – UN3480

The Li-G4 is classified as Class 9 dangerous goods according to UN3480, a power source with high energy density and hazardous materials in a sealed metal cabinet.

Installation must follow national safety regulations in accordance with the requirements for enclosure, installation, creepage, clearance, marking and segregation requirements for the end-use application. We recommend that installations are performed by authorised professionals. Switch off the system and check for hazardous voltages before changing any connections!
The Lithium Power Supply must only be serviced by trained personnel.

The lowest ingress protection rating for Li-G4 is IP54. Ensure that the installation of the Lithium Power Supply complies with IP54 requirements.

Observe the following:

Do not open the Li-G4.

Do not discharge a new Li-G4 until it has been fully charged.

Charge only within the specified limits.

Make sure the Li-G4 is switched off when it is moved and during installing.

Do not mount the Li-G4 upside down or on its side.

Check if the Li-G4 has been damaged during transport.

Do not leave outside exposed to the elements.

Do not use at altitudes above 2,000 metres (6,562 feet)

Do not allow children or animals to come in contact with the device or connected power supplies.

Danger in case of fire:

Danger of explosion with dust particles.

Decomposition due to fire or heat development emits toxic and corrosive gases.

Combustion gases which strongly irritate the eyes and respiratory organs.

General precautions the driver should observe if these hazards occur:

Switch off the motor.

Place a warning sign on the road to warn others.

Inform others of the dangers and advise them to stay away from the wind direction.

Contact the police and fire brigade immediately and inform them that there are lithium batteries (UN3480) onboard.

Instruction for fire extinguishing:

Extinguish fire with water. If possible, submerge the Li-G4 completely in water.

Extinguishing with water produces fluoride, phosphate, fluoride-oxide and carbon monoxide.

Alternatively, extinguish with a CO2 fire extinguisher.



**NON-SPILL
LI-ION BATTERY**

SAFETY INSTRUCTIONS – UN3480

CONTENT

1. GETTING STARTED

- 1.1 PRODUCT BOX CONTENTS
- 1.2 PRODUCT DETAILS

2. PRODUCT USAGE

- 2.1 INTERFACE
- 2.2 SYSTEM CONFIGURATION – STANDALONE (CHARGE FROM ACCUMULATOR)
- 2.3 SYSTEM CONFIGURATION – CAPACITY EXTENSION FOR LPS II
- 2.4 SYSTEM CONFIGURATION – BATTERY W. COMBI

3. TROUBLESHOOTING

- 3.1 ERROR LIST

4. SPECIFICATIONS

5. CHARGE PROFILE AND SETTINGS

6. SAFETY AND FUSES

7. CERTIFICATIONS AND COMPLIANCE

8. BATTERY MAINTENANCE

9. STORAGE

10. TRANSPORTATION

11. DISPOSAL

12. WARRANTY

**UNIT MUST BE CHARGED
EVERY 6 MONTHS IF NOT
USED**

1. GETTING STARTED

1.1 Product Box Contents

1x Li-G4 battery	2x M8 bolts (With washers)
2x M12 connectors	1x M4 bolt

1.2 Product Details

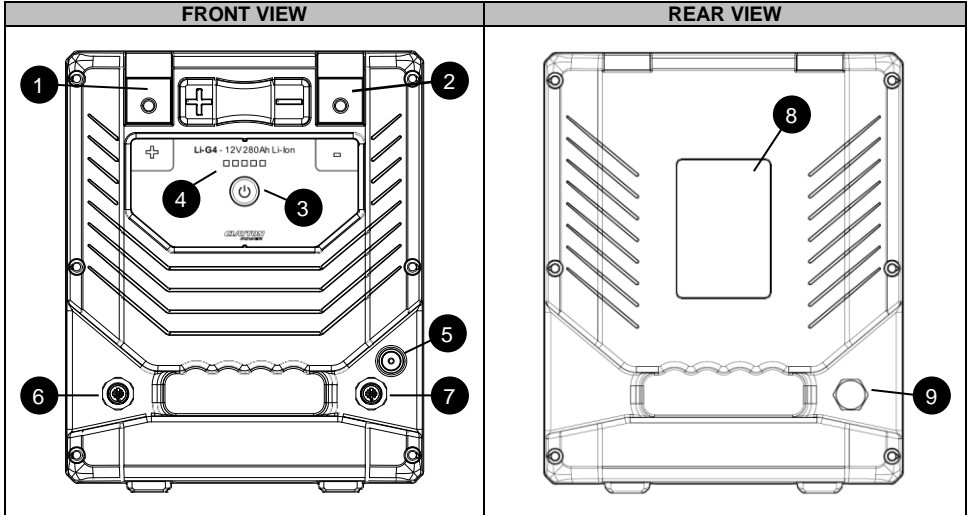

DESCRIPTION

1	Terminal (+)	8	Type plate
2	Terminal (-)	9	Pressure valve
3	Power button		
4	SOC indication		
5	Wake-up (M4 terminal)		
6	M12 – Data/IO connector (Isolated)		
7	M12 – Data/IO connector (Isolated)		

NOTE: The wake-up (M4 terminal) provides remote control for the battery's output. The battery turns on at voltages above 4V and turns off when the voltage falls below 3V.

M12 PINOUT

#	FUNCTION	FRONT VIEW
1	Single Wire	<p>The diagram shows the front view of the M12 connector with five pins labeled Pin 1 through Pin 5. Pin 1 is at the top, Pin 2 at the bottom, Pin 3 on the right, Pin 4 on the left, and Pin 5 in the center.</p>
2	I/O Signal	
3	GND	
4	CAN High	
5	CAN Low	

NOTE: All ports of the M12 connector are isolated and do not have any voltage potential reference to terminal voltage or terminal ground.

2. PRODUCT USAGE

Li-G4 is a module-based lithium iron phosphate battery (LiFePO₄/LFP) which is a safe and reliable chemistry for energy storage. The product is available in 2 variants with capacities of 100Ah and 280Ah to satisfy demanding applications. The nominal voltage of a Li-G4 module is 12.8V. The Li-G4 series has an integrated battery management system to protect the cells from deep discharge, overcharge and overheating. The product features:

- Safe battery technology – LiFePO₄.
- Integrated Battery Management system.
- Integrated power switch.
- Designed for heavy duty environments and requirements.
- Metal frame and flame-retardant enclosure.
- CAN bus communication (compliant with SAE J1939) which is used for:
 - Control
 - Synchronization (System configuration)
 - Data logging
 - Firmware update

Ensuring the safe installation of lithium batteries is mandatory to prevent any potential hazards. The battery comes equipped with built-in protection mechanisms, including short-circuit and overcurrent protection, as well as an internal fuse that is not user-replaceable.

ATTENTION:

It is mandatory to add an additional fuse as close as possible to the positive terminal, with a rating that aligns with your power requirements.

2.1 Interface

The battery is equipped with a button and LED for operation and indication. The battery is considered off when no LED is illuminated in the State of Charge (SoC) indication bar. When the device is turned on, the SoC indication bar will display the remaining battery capacity in 20% increments. Following table explains normal operation and warnings that are indicated by the SoC indication bar:

LED	BEHAVIOUR	INDICATION
Green LEDs	Solid	Battery is active and 5 LEDs show State of Charge.
	Flashing	Battery is charging and 5 LED's show State of Charge.
Red LEDs	Solid	Battery is active but too cold for charging, 5 LED's show State of Charge.
1 Red LED	Solid	Battery is nearly empty (<10% SOC)
	Flashing	Battery is empty and disconnected

The SoC indication bar also serves to display error codes. An error will trigger a red flashing SoC indication bar, with the number of flashes corresponding to the specific failure. You can find a list of error codes on chapter 3.1. Errors can be cleared by turning the battery off and on, depending on the type of error.

2.2 System configuration – Standalone (Charge from accumulator)

The Li-G4 can be used as a standalone power source for auxiliary appliances. The following diagram illustrates how to connect the battery to an accumulator for charging during a drive. To control the charging process, a Clayton Power DC-DC converter (**PN: CD1804**) is used. This converter prevents the system from draining the accumulator and only charges it when the voltage is within specified limits and a wake-up signal (Pin 2 – M12 connector) is present.

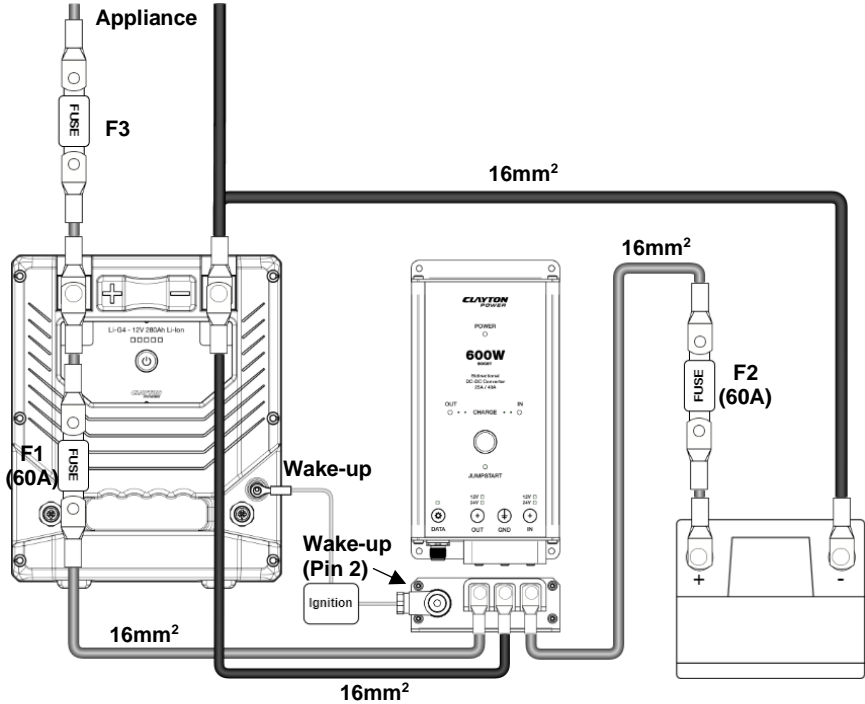

Connect appliances to the terminals of the battery and use an appropriate cable thickness with fuse (F3) that supports the appliances current.

ATTENTION:

- M8 bolts must be torqued to 12Nm
- M4 bolts must be torqued to 1.5Nm
- Do not connect the CAN Bus to the vehicle's CAN communication system.
- Place fuses as close to the source as possible.

2.3 System configuration – Capacity extension for LPS II

Li-G4 can be used to extend the capacity of LPS II series. Use Clayton Power DC-DC converter between the batteries and the LPS. Connect according to image:

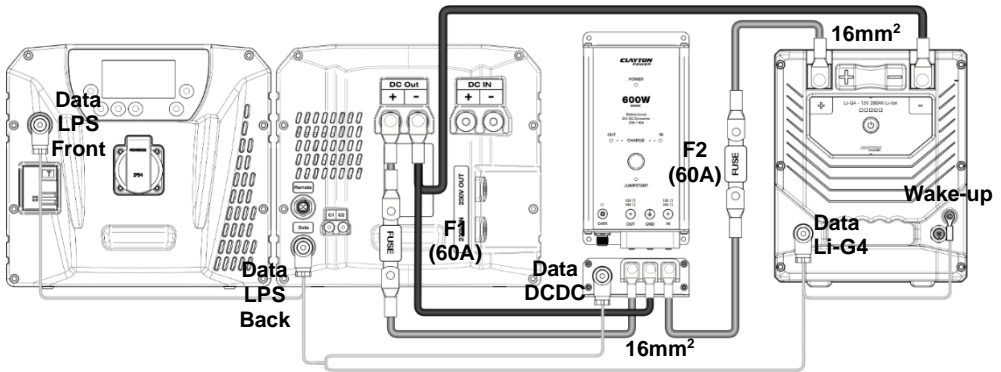

Use 16mm² cable gauge fused with 60A fuse as close to the source as possible.

If the LPS is used to run heavy equipment that requires constant high power, a larger DCDC converter can be used to enable power transfer between the batteries and the LPS to keep up with the consumption. Using PN: **CD1804**, the power transfer is limited to 45A, while PN: **CD2402** allows power transfer up to 90A. The installation using PN: **CD2402** is illustrated in the following diagram:

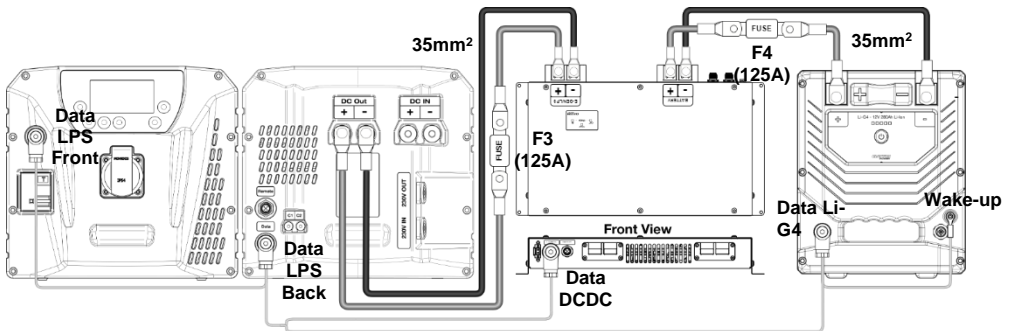

Use 35mm² cable gauge fused with 125A fuse as close to the source as possible.

The communication / signal harness for both configurations is the same and is premade (**PN: AL2401**) and is constructed according to following table:

DESCRIPTION	Data LPS Front (Pin #)	Data DCDC (Pin #)	DATA Li-G4 (Pin #)	Wake-up Li-G4	Data LPS Back (Pin #)
Charge	2	1	-	-	-
Discharge	-	2	2	-	2
GND	-	3	3	-	3
CAN High	-	4	4	-	4
CAN Low	-	5	5	-	5
Wake-up	-	-	2	Terminal	-

ATTENTION:

- M8 bolts must be torqued to 12Nm
- M4 bolts must be torqued to 1.5Nm
- Do not connect the CAN Bus to the vehicle's CAN communication system.
- Place fuses as close to the source as possible

Configuration on LPS:

To enable the capacity extension, you must change a setting on the LPS through its interface/display. Go to:

Main Menu → General → System Configuration

and set the configuration to "Capacity Extension". This will enable the capacity extension functionality. To disable the capacity extension functionality select "None".

2.4 System configuration – Battery w. Combi

The Li-G4 can be used with a G3 Combi for 230VAC applications. Using a Clayton Power DC/DC converter (PN: **CD1803**) between the Li-G4 and the vehicle battery allows charging during driving. The battery can be charged using the Combi (Blue Neutrik) or from an accumulator.

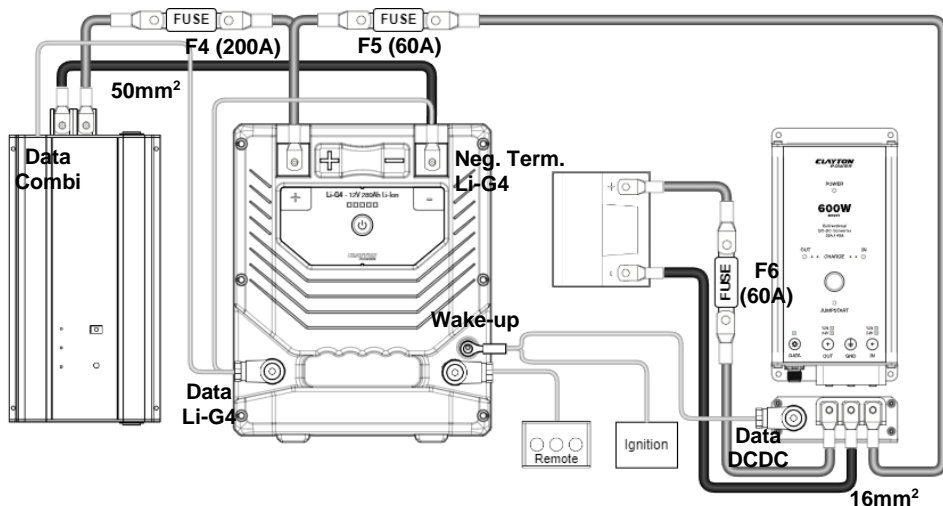

Use 50mm² cable gauge with a 200A fuse between Li-G4 and Combi. Use 16mm² cables with 60A fuses between Li-G4, DCDC converter and accumulator. Place the fuses as close to the source as possible.

Wire the communications / control signals according to following table:

DESCRIPTION	Data Combi (Pin #)	Data Li-G4 (Pin #)	Neg. Term. Li-G4	Wake-up Li-G4	Data DCDC (Pin #)
Single Wire	1	1	-	-	-
Wake-up	-	-	-	Terminal	2
GND	-	3	Terminal	-	-

ATTENTION:

- M8 bolts must be torqued to 12Nm
- M4 bolts must be torqued to 1.5Nm
- Do not connect the CAN Bus to the vehicle's CAN communication system.
- Place fuses as close to the source as possible

3. TROUBLESHOOTING

3.1 Error List

The battery uses its LEDs for error indication. An error list shows the cause of failure and how to solve the error. If the solutions provided below are unable to resolve the error or if the error code is not listed, contact your retailer.

FLASHES	DESCRIPTION	SOLUTION
2	Unit temperature out of range	Let the device warm up / cool down or move it to a place with a higher / lower ambient temperature
3	Overload, Short Circuit or Pre-charge failure	Disconnect the load and restart the battery to confirm operation. Check for short circuits in installation or defective connected equipment
4	IO Terminal is overloaded or is short circuited	Disconnect connector and check connector or cable for damage
5	Blown internal fuse or defective internal switch	Contact your retailer for assistance
6	Other failures	Contact your retailer for assistance

Errors can be cleared by turning the battery off and on, depending on the type of error.

4. SPECIFICATIONS

PARAMETER	Li-G4 2S (100Ah)	Li-G4 2S (280Ah)
Model no.	CB2301	CB2303
Type	Rechargeable Lion battery system	
Chemistry	LiFePO4	
Number of cells	4	
Capacity	100 Ah (1,280 Wh)	280 Ah (3,584 Wh)
Available capacity	80 Ah (1,024 Wh)	235 Ah (3,008 Wh)
Nominal voltage	12.8 VDC	
Operation voltage	10.8 - 14.4 V DC	
Discharge current - Continuous	175 A	200 A
Discharge current - 1 min.	400 A	400 A
Charging current - Continuous	100 A	140 A
Cycle Life (80%DOD)	>2800 cycles (EOL = 60%) 0,75C charge 1,75C discharge	>2800 cycles (EOL = 70%) 0,3C charge 0,5C discharge
Cooling	Passive	
Operating temperature discharge	-20 ~ 50°C	
Operating temperature charge	0 ~ 50°C	
Operating mode consumption	< 45mA	
Sleep mode consumption	< 25mA	
Parallel connection	Not supported	
Serial connection	Not supported	
Marking (IEC 61960)	4IFpP51/161/119	4IFpP73/175/208
Marking (IEC 62620)	IFpP/51/161/119/[4S]M/- 20+60/90	IFpP/73/175/208/[4S]M/- 30+60/90
Communication	CAN Bus (SAE J1939)	
I/O ports	2 x I/O and 1 x Input	
I/O input voltage	0 - 60 V	
I/O output voltage	0 - 12 V	
I/O output current	400mA (Over current protected)	
I/O connector type (M12)	Type A - 5-way	
I/O connector type (Terminal)	M4	
IP classification	IP54	
Maximum altitude	2,000 m	
Product weight	12 kg	28 kg
Product size (H x W x L)	187 x 197 x 343	243 x 197 x 438
Gross weight	14 kg	30 kg
Package size (H x W x L)	240 x 260 x 450 mm	400 x 260 x 545 mm

5. CHARGE PROFILE AND SETTINGS

The recommended charging parameters for the charging sources are:

- **Li-G4 2S (100Ah):** 50A constant current (Max. 100A - 1 cycle/day), 14.4V constant voltage.
- **Li-G4 2S (280Ah):** 56A constant current (Max. 140A - 1 cycle/day), 14.4V constant voltage.

For more information on the charge settings of the individual chargers or inverters/chargers, please refer to the manuals on the respective product page.

6. SAFETY AND FUSES

These measures ensure the safe and secure operation of the electrical system:

- Correct orientation - Do not place the battery upside down.
- Incorrect cable size or bad cable connection can cause thermal issues or short circuits.
- Make sure the Li-G4 battery is turned off before starting the installation and do not connect any active wakeups before the installation is finished.
- Do not combine Li-G4 batteries with other brands.

ATTENTION: DC terminals are protected with 400A fuse in Li-G4 2S. The internal fuse cannot be replaced by user and requires service. Place a correctly dimensioned fuse as close as possible to the Li-G4 to prevent high current short-circuits and internal fuse to blow.

Battery operation is monitored by the battery management system to ensure safe operation. The integrated battery management system disconnects the power line in case of any abnormalities.

		Li-G4 2S (100Ah)	Li-G4 2S (280Ah)
Overvoltage	Overvoltage warning for each cell	3.60 V	
	Overvoltage protection for each cell	3.65 V	
	Overvoltage release for each cell	3.55 V	
	Overvoltage recovery method	Automatically when cell voltage falls below release voltage	
Undervoltage	Undervoltage warning for each cell	2.70 V	
	Undervoltage protection for each cell	2.50 V	
	Undervoltage release for each cell	2.80 V	
	Undervoltage recovery method	Automatically when cell voltage rises above release voltage	
Cell balancing	Cell balancing method	Passive Balancing	
	Cell balancing current	1 A	
Over current	Charge over current protection (Time delayed)	>100 A	>140A
	Discharge over current protection (Time delayed)	>175 A	>200A
Battery temperature	Over temperature protection for each cell	65°C	
	Under temperature protection for each cell	-30°C	

7. CERTIFICATIONS AND COMPLIANCE

Low Voltage Directive 2014/35/EU

EN62368-1, EN62133

RoHS Directive 2011/65/EU

EN 63000

EMC 2014/30/EU

EN61000-6-2, EN61000-6-3

E-Marking

UN-ECE Regulation 10, E5 10R – 06
0488



8. BATTERY MAINTENANCE

To ensure optimal battery performance, fully recharge the battery every month (100%). If the battery has not been fully charged for a long period, maintenance charge can be prolonged to several days.

9. STORAGE

The battery can be stored at temperatures between -20°C and 45°C. For long term storage (>1 month), the battery should be fully charged and stored at temperatures between 0°C and 35°C. **The battery needs to be charged every 6 months if not used.** Do not store the battery upside down.

10. TRANSPORTATION

Lithium batteries are classified as Class 9 hazardous materials (UN3480) and must always be transported in compliance with all applicable local, national, and international regulations. Proper packaging is required during transportation, and packaging instructions (PI965) must be respected. The batteries should not be turned upside down during transportation.

11. DISPOSAL

To ensure proper disposal and reduce potential hazards, discharge the battery completely before placing it in a designated battery recycling bin. Improper disposal, such as throwing it in regular rubbish bins, is strictly prohibited as the product contains batteries with potentially harmful chemicals. Adhere to local laws and regulations for battery recycling and disposal.

12. WARRANTY

IMPORTANT AND WARNING:

DO NOT USE OR ATTEMPT TO USE THIS PRODUCT UNTIL YOU HAVE READ THE USER MANUAL IN ITS ENTIRETY. IMPROPER INSTALLATION OR USE OF THIS DEVICE MAY BE DANGEROUS AND MAY CAUSE DAMAGE TO OTHER ELECTRICAL EQUIPMENT AND WILL VOID THE WARRANTY.

Warranty. The company guarantees that products and associated services are free of significant defects in design, material and execution for 24 months after delivery.

Exceptions. The company's warranty does not include defects caused by: (i) ordinary wear and tear, (ii) storage, installation, use or maintenance against the company's instructions or ordinary practice, (iii) repair or change carried out by others than the company, and (iv) other conditions for which the company has no responsibility.

Examination. Within a reasonable period of time after receiving a complaint from the client about defects and examining the claim, the company will inform the client about whether or not the defects are covered by the warranty. After the request, the client must ship defect parts to the company. The client covers the expenses and risks of the parts during transport to the company. The company covers the expenses and risks for return of parts during transport, only if the defects are covered by the warranty.

Register a complaint. If the client discovers defects within the period of warranty, which the client wishes to invoke, it must be communicated immediately in writing. If defects, which the client discovers or should have been discovered, are not immediately communicated to the company in writing, it cannot be effectuated at a later time. The client must provide the company the requested information about the registered defects.

Instructions for Obtaining Warranty Service for Clayton Power Devices

To obtain warranty service, contact the store where you have bought the product and provide the following:

- Sales receipt
- Device model number
- Device serial number
- Brief description of the application and problem, including any error codes displayed on the device.
- Obtain an authorisation number from the Clayton Power dealer before shipping the device. Carefully pack the device and ship it (freight paid) to the Clayton Power dealer. Note that the device contains lithium batteries and must be shipped as dangerous goods according to UN3480 lithium-ion batteries' regulations.

Sales: sales@claytonpower.com

Service: service@claytonpower.com

Phone: +45 4698 5760



CLAYTON
POWER